

Oil Press. Gauge

Package Contents

Gauge*1 / Pressure Sensor*1 / Sensor Wire (3pin)*1 / Power Box*1 / Gauge Wire (6pin)*1 / Operation Manual*1

Installation Diagram

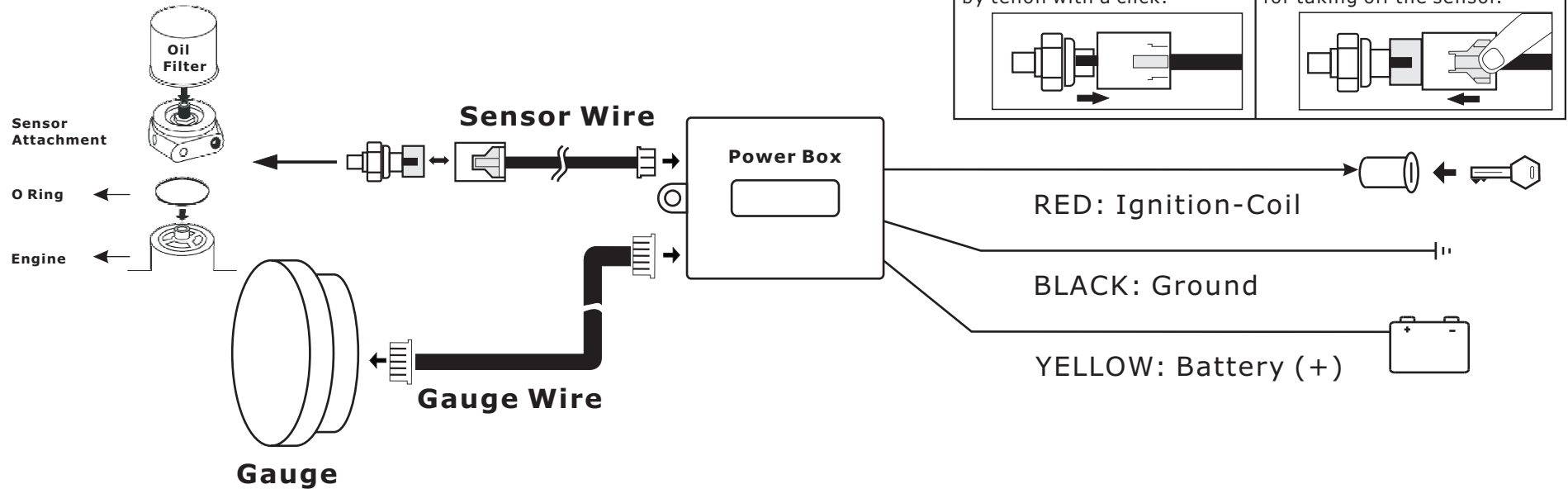

To avoid damage, please ensure the RED wire is attached to the ignition switch that connected to Coil.

Ignition Switch Diagram

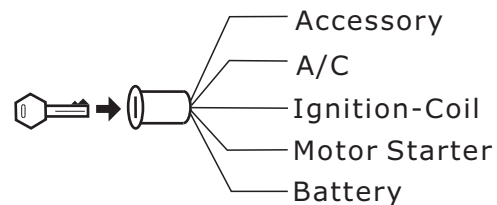

⚠ WARNING

1. Please must follow all installations in this manual to ensure safe installation and operation of the product.
2. DO NOT disassemble or reassemble the product. This might cause damage or make them unsafe to use. When the product is disassembled or reassembled, the Warranty can't be offered.
3. Before installation, please make sure the engine is switched off and the vehicle is stationary.
4. Due to possible injury from contact with a hot engine or exhaust pipe, DO NOT begin installation until the vehicle is cool.
5. When attaching wires for the product, please take care so that the product's wires do not interfere with existing wires.
6. This product is only for use on vehicles with 12V electronic system.

⚠ CAUTION





1. To avoid oil leaks during installation of sensor, please use Telfon tape while installation. Before driving, inspect tubing and oil blocks for leaks. Leaks could cause a fire or damage the engine.
2. To avoid oil leaks, please ensure the size of adaptor is suited.
3. To avoid the damage of sensor wire, please fix the waterproof connector on the vehicle body.
4. Oil spills by the installation work. Please replenish the engine with oil. The engine might overheat when oil is too little.

Remote Controller Operation Manual - Oil Press. Gauge





Tips of Remote Controller Operation

1. Please have the remote controller point to the gauge you are going to set up.
2. In setting process, idle any button for 5 seconds or press  directly; the gauge will leave setting mode and save automatically.
3. A "beep" sound will be heard while the new setting is done.







• Color Setting

1. Select Oil Press. Gauge icon by press  on Remote Controller.
2. Then press  for entering the color selection mode. Again, press the  for different color selection. Press  or idle any button for 5 seconds to leave the setting mode.





• Brightness Adjust Setting

1. Select Oil Press. Gauge icon by press  on Remote Controller.
2. Then press  for entering the color selection mode. Long press  to increase the brightness or long press  to decrease. Press  or idle any button for 5 seconds to leave the setting mode.

• Warning Value Setting (When the value is below, the warning will be functional)

1. Select Oil pressure Gauge icon by press  on Remote Controller.
2. Press  or  for entering the warning setting mode. Press  or  to adjust the warning value. Press  or idle any button for 5 seconds to leave the setting mode.

• Peak Value Setting

1. Select Oil Press. Gauge icon by press  on Remote Controller.
2. Press  to display peak value record, or, press  to clear peak value record. Press  or idle any button for 5 seconds to leave the setting mode.